

BEARINGS - REMOVAL/INSTALLATION**1. Bearings Removal/Installation****A. Remove the Bearing (Refer to Figure 401).**

- (1) Remove the bearing with its supporting bracket or component housing from the airplane, refer to the applicable chapter.
- (2) Push the worn bearing from its housing or supporting bracket.
- (3) After you remove the bearing, examine the component housing or bracket for structural damage (cracks, warpage or bends).
- (4) Examine the hole in the housing for damage, cracks or other abnormal conditions of the material and hole diameter.

NOTE: The gap between the bearing outside diameter and the hole inside diameter must be within 0.0010 to 0.0035 inch.

B. Install the Bearing (Refer to Figure 401, Figure 402, Figure 403, and Figure 404).

NOTE: The new bearings must stay in their packages until the time of the actual installation.

CAUTION: Do not let the cleaner penetrate into the bearing. This will remove the lubrication from the bearing.

- (1) Clean the outer surfaces of the bearing and hole in the component housing with a clean cloth and remove all traces of oil or grease.

NOTE: The cloth must be moist with an approved cleaning solvent.

- (2) Use a clean cloth to dry the bearing and hole.

CAUTION: Make sure that the retaining compound does not go into the bearing.

- (3) Apply retaining compound to the outer surface of the bearing and the mating surface of the hole in the housing. Refer to the Application of Fastener Retaining Compounds and Table 401.

- (4) Push the bearing into position.

- (5) Use a staking tool to stake the bearing in place.

- (a) Stake between the current stake marks around the hole (refer to Figure 404).

- (b) If a new component housing or bracket is necessary, stake the bearing in the same pattern as the original installation.

- (c) If the bearing is not kept in position on the opposite side of the stake (refer to Figure 402), use a support during the staking operation (refer to Figure 403).

- 1 Stake the bearing housing on both sides only if the bearing is not kept in position on the opposite side of the stake.

- (6) Install the bearing component or bracket assembly on the airplane, refer to the applicable chapter.

C. Riveted-On Bearing Brackets or Housings:

- (1) The replacement bearing brackets, housings or bearing and bracket assemblies can be supplied without holes. The riveted installation must be put into position and drilled.

NOTE: If you replace a bearing that is attached with rivets, the alignment of the removed bracket must be marked. The new bracket must be installed in the original alignment.

2. Application of Fastener Retaining Compounds**A. General**

- (1) This procedure gives general methods to apply materials used to seal, lock and keep metal parts in position. The retaining compounds cure anaerobically, that is, they will become hard only when put between properly prepared mating surfaces where no air can touch the retaining compound. Refer to Table 401 for the retaining compounds and surface primers included in this procedure.

CAUTION: Make sure that the primer and retaining compounds do not touch the synthetic rubber.

CAUTION: Make sure that the primer and retaining compounds do not go into the bushings or bearings.

NOTE: It is not necessary to apply primer to surfaces other than cadmium, zinc, anodized or corrosion-resistant steel.

NOTE: For optimum strength properties, the gap between the bushing (bearing) outside diameter and

the housing hole inside diameter must be within 0.0010 to 0.0035 inch.

NOTE: Primer and retaining compounds must be kept in an enclosed building that will give the containers protection from direct sunlight, wind and rain.

Table 401. Primer and Retaining Compounds

LOCQUIC SURFACE PRIMER - MIL-S-22473	GRADE	FORM	COLOR	APPLICATION
Primer (Catalog Number 747-56)	T	R	Yellow	(Ready to use) Can be used with Loctite 609 or 680 and Permabond HL038 or HH020.
RETAINING COMPOUND - MIL-R-46082	MANUFACTURER			APPLICATION
Loctite 609	Loctite Corp. Newington, CT 06111			Used as high strength retaining compound that cures quickly for studs, bearings and bushings.
Loctite 680	Loctite Corp.			Used as extra-high strength retaining compound that cures quickly for press fits on cylindrical parts.
Permabond HL038	Permabond International Corp. 480 S. Dean Street Englewood, NJ 07631			Used as high strength retaining compound that cures quickly for studs, bearings and bushings.
Permabond HH020	Permabond International Corp.			Used as extra-high strength retaining compound that cures quickly for press fits on cylindrical parts.

3. Bearing/Bushing Retention

A. Preparation

(1) Prepare the parts to be kept as follows:

- (a) Before you apply retaining compound to a surface, clean it with an approved cleaning solvent. Use a clean cloth and remove all traces of grease or oil.
- (b) Keep contamination from the cleaned surfaces, especially if they are not assembled immediately after they are cleaned.
- (c) Do not touch the clean parts with your bare hands. Use a clean cloth or clean white cotton gloves when you assemble the mating parts.

CAUTION: Primer has a chemical effect on materials such as thermoplastics or titanium.

NOTE: Some materials that are affected by softening or crazing include vinyl, cellulosic, styrene and methacrylate plastics. Thermosetting plastics are not affected.

B. Locquic Primer

NOTE: Cadmium, zinc, anodized, corrosion resistant steel and plastic surfaces must be primed with Locquic primer, Grade T, Form R (yellow).

- (1) Apply MIL-S-22473 Locquic primer, Grade T, Form R (yellow), to all surfaces that touch. Do not apply the primer to the oil grooves or ports of the bearings.
- (2) Let the surfaces air dry at room temperature for a minimum of 30 minutes.

C. Installation

NOTE: Bearings or bushings can be installed dry and the retaining compound applied as stated in the following step. Or a thin coat of retaining compound specified for repair can be applied to the primed surfaces that are to be joined and assembled wet.

- (1) After the installation (wet or dry), apply MIL-R-46082 retaining compound.
 - (a) Touch the application nozzle of the retaining compound container to the mating joint between the bearing

outside diameter and the housing.

NOTE: The compound will go into the joint by capillary action. When a ring of compound stays just outside the joint, the capillary penetration is complete.

4. Sealant and Retaining Compounds

A. Cure Methods

(1) Two methods to cure sealant and retaining compounds are:

(a) Method 1 - The parts must stay undisturbed for 24 hours at room temperature to get to full strength.

NOTE: If the bearing or bushing moves out of position before the full cure of the retaining compound is complete, the parts must be cleaned, primed and assembled again.

(b) Method 2 - The parts must cure at 275°F, +10° or -10°F for 15 minutes after the part gets to the necessary temperature.

(c) Examine the bearing for damage before it is put into position.

NOTE: Any damaged area of the bearing must be repaired before it is put into position.

(d) Lubricate the bearing or bushing after the retaining compound has cured.

Figure 401 : Sheet 1 : Bearing Removal and Installation

A2869

CENTER THE BEARING CAREFULLY IN THE HOUSING. THE BEARING SHALL NOT BE CANTED IN THE HOLE, AND IT SHALL NOT BE BOUND.
APPLY THE INSTALLING LOAD TO THE OUTER RACE OF THE BEARING.

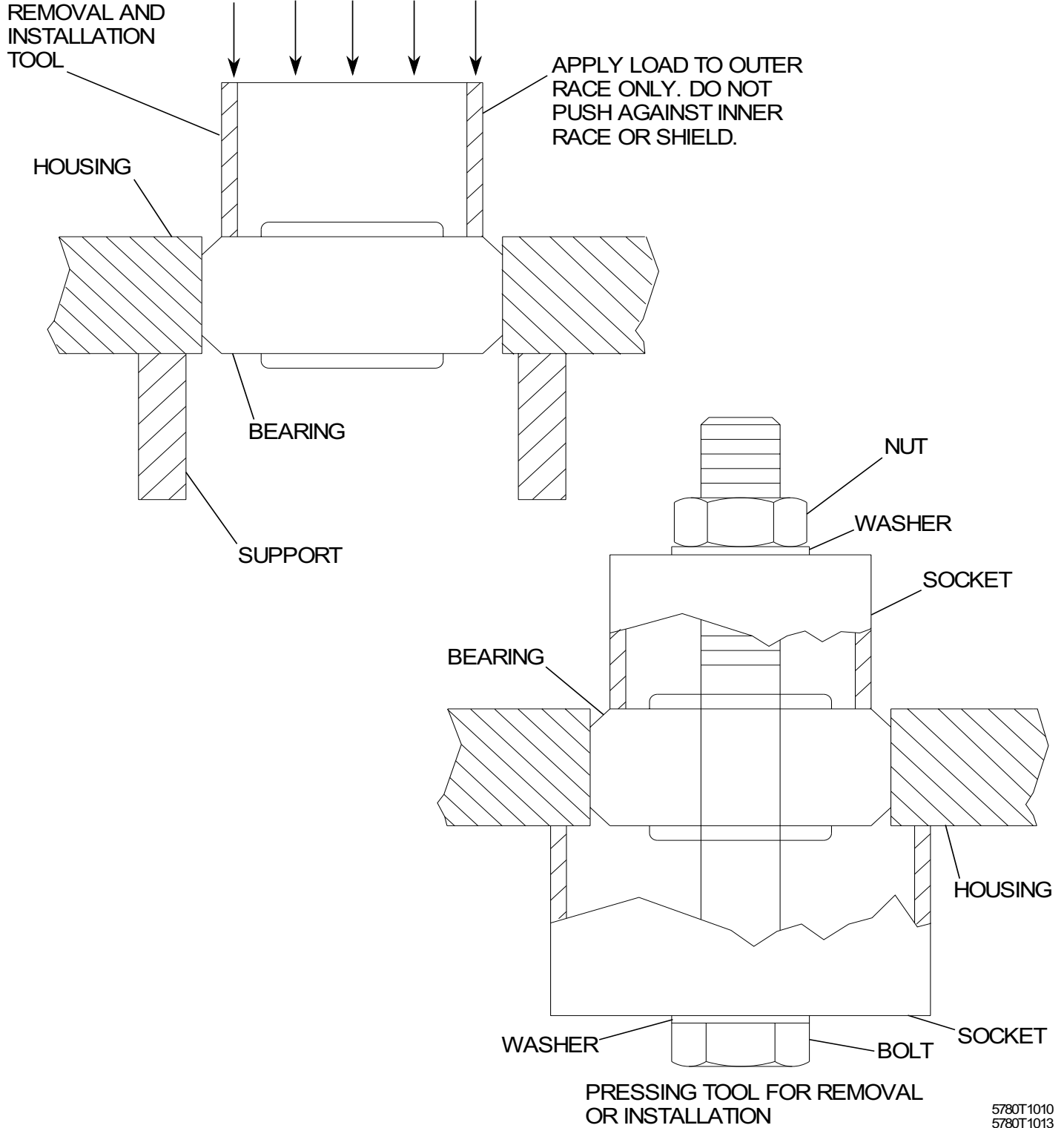

5780T1010
5780T1013

Figure 402 : Sheet 1 : Staking Dimension

A2875

THE DEPRESSIONS SHALL BE CONCENTRIC WITH THE BORE OF THE BEARING, WITHIN 0.020 TOTAL INDICATOR READING.

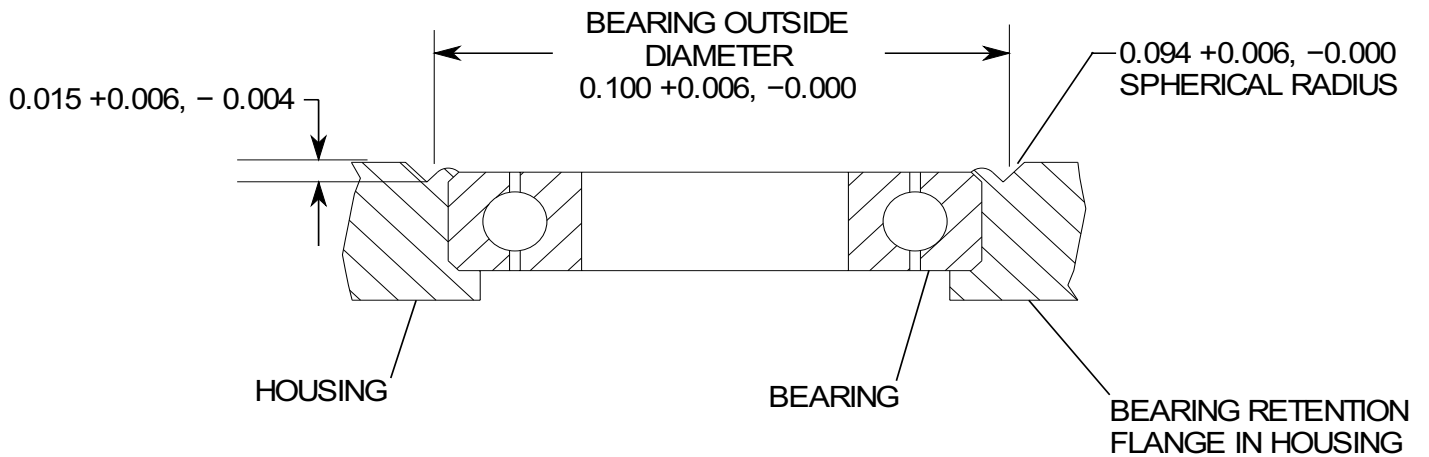

5780T1010

Figure 403 : Sheet 1 : Support During Staking

A2879

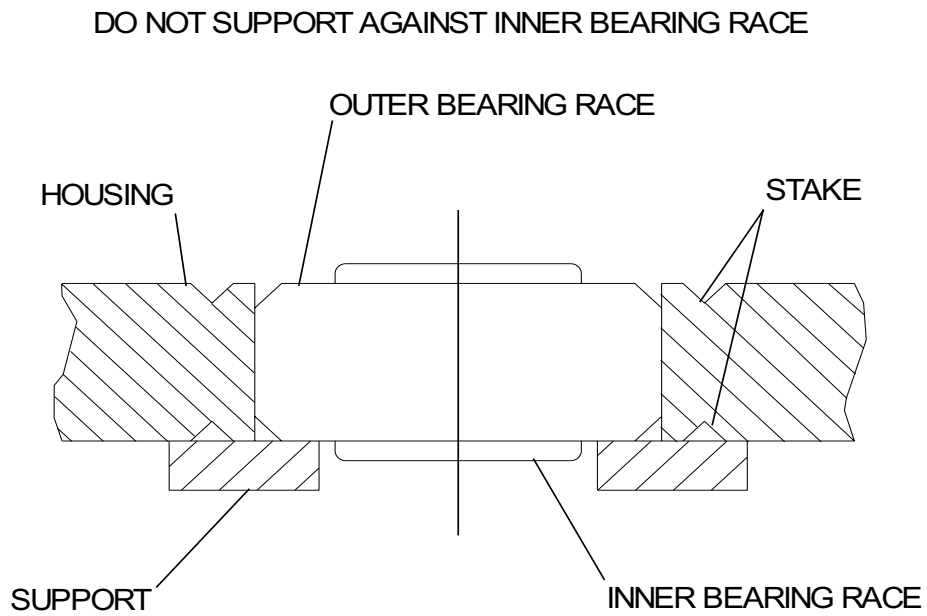

5780T1009

Figure 404 : Sheet 1 : Staking Tool - Typical

A13531

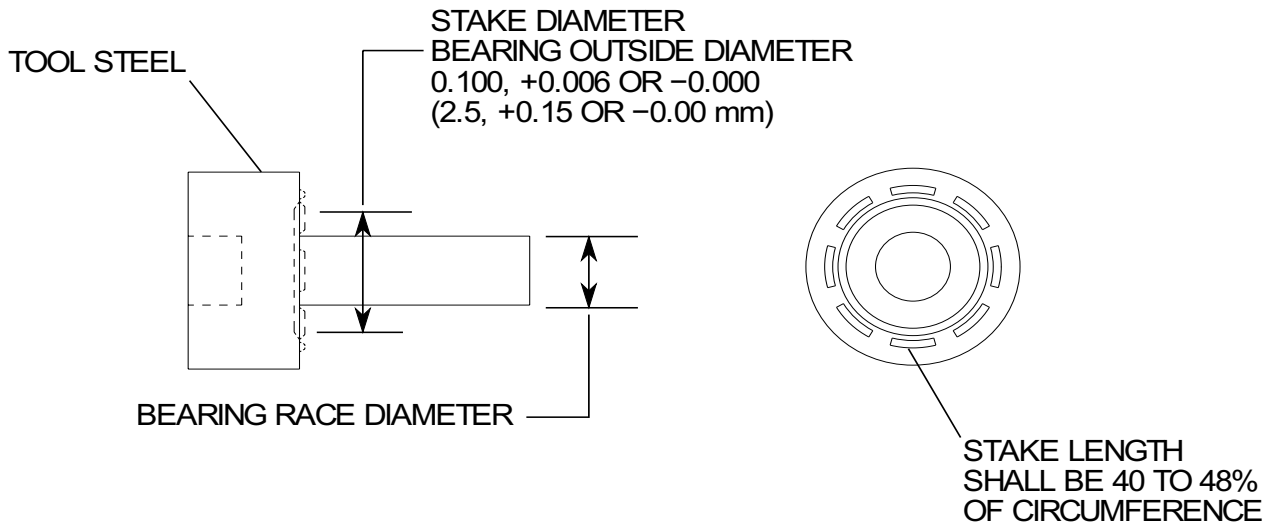

BEARING OUTSIDE DIAMETER	NUMBER OF STAKES
UP TO 0.734 (18.6 mm)	4
0.735 TO 0.984 (18.7 TO 25.0 mm)	6
0.985 TO 1.234 (25.1 TO 31.3 mm)	8
1.235 TO 1.690 (31.4 TO 42.9 mm)	10
1.691 TO 1.984 (43.0 TO 50.4 mm)	12

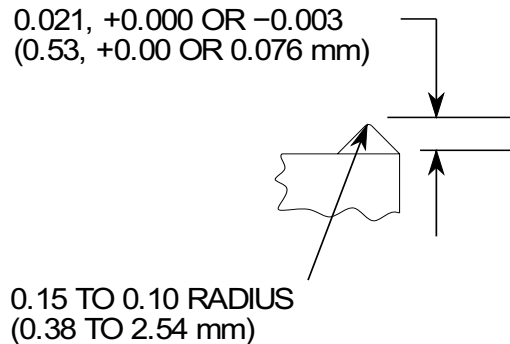
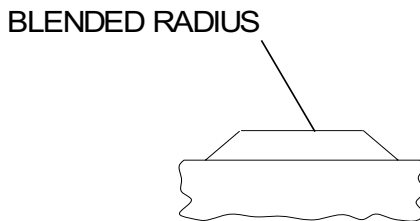
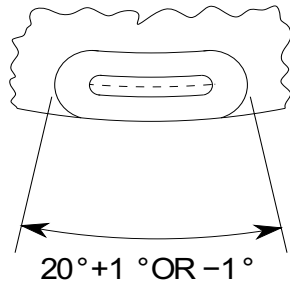

STAKE DETAIL

NOTE: ALL DIMENSIONS EXPRESSED IN INCHES

5780T1008
 5780T1008A
 5780T1008B